

## Modular Cooking Range Line thermaline 80 - 14 lt Well Freestanding Electric Deep Fat Fryer, 1 Side, H=800

ITEM # \_\_\_\_\_

MODEL # \_\_\_\_\_

NAME # \_\_\_\_\_

SIS # \_\_\_\_\_

AIA # \_\_\_\_\_



**588330 (MAFGADDAO)** 14lt electric Deep Fat Fryer,  
 one-side operated

### Short Form Specification

**Item No.** \_\_\_\_\_

Unit constructed according to DIN 18860\_2 with 20 mm drop nose top and 70 mm recessed plinth. Internal frame for heavy duty sturdiness in stainless steel. 2 mm top in 1.4301 (AISI 304). Flat surface construction, easily cleanable. THERMODUL connection system enables seamless worktop when units are connected and avoids soil penetrating. Appliance designed to deep fry meat, fish and vegetables (french fries). Deep drawn V-shaped well with external heating elements to facilitate cleaning operations. Indirect oil heating system and uniform heat distribution for extended oil life. Electronic sensor for precise oil temperature control. Reduced power setting to melt solid fat. Oil can be easily drained via a ball-valve. All-round basin raised edges to protect against soil infiltration. Large overflow stamped area around the well. Overheat protection switches off the supply in case of overheating. Standby function saves energy and quickly recovers maximum power. Metal knobs with embedded hygienic silicon "soft" grip enable easier handling and cleaning. IPX5 water resistant certification.  
 Configuration: Freestanding, one-side operated.

### Main Features

- Deep drawn V-Shaped well.
- Large overflow stamped area, located around the well.
- External heating elements allow to easily clean the well.
- Overheat protection: the temperature sensor switches off the supply in case of overheating.
- Indirect oil heating system and uniform heat distribution to guarantee extended oil life.
- All major components may be easily accessed from the front.
- Reduced power setting to melt solid fat.
- Oil level mark for MAX/MIN filling.
- Designed for deep fat frying of meat, fish, specialities and vegetable (french fries, chips).
- Oil can be drained off via a ball-valve with a lock to prevent unintentional opening. When opened, the ball valve provides a full cross-section opening to easily clean the drainage system.
- THERMODUL connection system creates a seamless work top when units are connected to each other thus avoiding soil penetrating vital components and facilitating the removal of units in case of replacement or service.
- Metal knobs with embedded hygienic "soft-touch" grip for easier handling and cleaning. The special design of the controls prevents infiltration of liquids or soil into vital components.
- Large visible digital display manufactured in tempered glass to resist heat and chemicals, showing temperatures or power settings. The display also shows on/off status of the appliance and on/off status of the heating elements.
- Raised edge all around the well to protect from infiltration of dirt from worktop.
- Electronic sensor for precise oil temperature control.

### Construction

- 2 mm top in 1.4301 (AISI 304).
- Unit constructed according to DIN 18860\_2 with 20 mm drop nose top and 70 mm recessed plinth.
- Flat surface construction with minimal hidden areas to easily clean all surfaces
- IPX5 water resistance certification.
- Internal frame for heavy duty sturdiness in stainless steel.

### Sustainability



- Standby function for energy saving and fast recovery of maximum power.
- This model is compliant with Swiss Energy Efficiency Ordinance (730.02).

**APPROVAL:** \_\_\_\_\_

Front

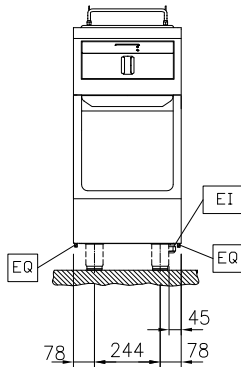

Side

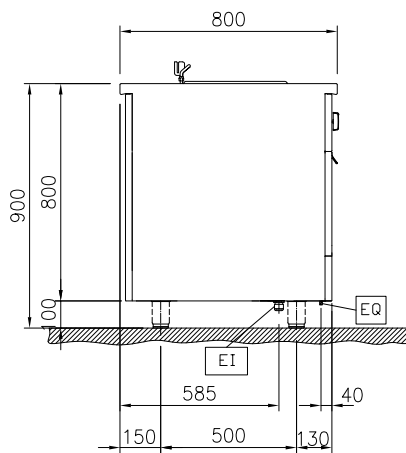

EI = Electrical inlet (power)  
 EQ = Equipotential screw

Top

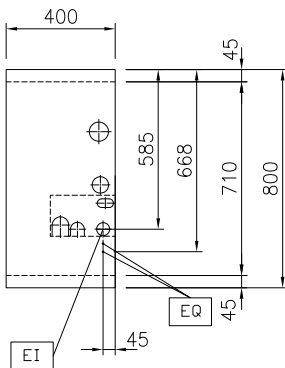

### Electric

Supply voltage: 400 V/3N ph/50/60 Hz  
 Total Watts: 10 kW

### Key Information:

Number of wells: 1  
 Usable well dimensions (width): 240 mm  
 Usable well dimensions (height): 225 mm  
 Usable well dimensions (depth): 380 mm  
 Thermostat Range: 100 °C MIN; 180 °C MAX  
 External dimensions, Width: 400 mm  
 External dimensions, Depth: 800 mm  
 External dimensions, Height: 800 mm  
 Net weight: 65 kg  
 Configuration: On Base; One-Side Operated

### Sustainability

Current consumption: 14.4 Amps

**Included Accessories**
**Optional Accessories**

- |  |            |                          |   |            |                          |
|--|------------|--------------------------|---|------------|--------------------------|
| • Discharge vessel for 14 & 23lt fryers  | PNC 911570 | <input type="checkbox"/> | • Endrail kit, (12.5mm), for back-to-back installation, right   | PNC 913250 | <input type="checkbox"/> |
| • Lid for discharge vessel 14 & 23lt fryers  | PNC 911585 | <input type="checkbox"/> | • Endrail kit, flush-fitting, for back-to-back installation, left   | PNC 913253 | <input type="checkbox"/> |
| • Connecting rail kit, 800mm   | PNC 912500 | <input type="checkbox"/> | • Endrail kit, flush-fitting, for back-to-back installation, right  | PNC 913254 | <input type="checkbox"/> |
| • Stainless steel side panel, 800x800mm, freestanding  | PNC 912508 | <input type="checkbox"/> | • Side reinforced panel only in combination with side shelf, for freestanding units   | PNC 913257 | <input type="checkbox"/> |
| • Portioning shelf, 400mm width  | PNC 912522 | <input type="checkbox"/> | • Side reinforced panel only in combination with side shelf, for back-to-back installations, left   | PNC 913273 | <input type="checkbox"/> |
| • Portioning shelf, 400mm width  | PNC 912552 | <input type="checkbox"/> | • Side reinforced panel only in combination with side shelf, for back-to-back installation, right   | PNC 913274 | <input type="checkbox"/> |
| • Folding shelf, 300x800mm   | PNC 912577 | <input type="checkbox"/> | • Filter W=400mm  | PNC 913663 | <input type="checkbox"/> |
| • Folding shelf, 400x800mm   | PNC 912578 | <input type="checkbox"/> | • Stainless steel dividing panel, 800x800mm, (it should only be used between Electrolux Professional thermaline Modular 80 and thermaline C80)  | PNC 913669 | <input type="checkbox"/> |
| • Fixed side shelf, 200x800mm  | PNC 912583 | <input type="checkbox"/> | • Electric mainswitch 25A 4mm <sup>2</sup> NM for modular H800 electric units (factory fitted)  | PNC 913676 | <input type="checkbox"/> |
| • Fixed side shelf, 300x800mm  | PNC 912584 | <input type="checkbox"/> | • Stainless steel side panel, 800x800mm, flush-fitting (it should only be used against the wall, against a niche and in between Electrolux Professional thermaline and ProThermetic appliances and external appliances - provided that these have at least the same dimensions) | PNC 913685 | <input type="checkbox"/> |
| • Fixed side shelf, 400x800mm  | PNC 912585 | <input type="checkbox"/> |   |            |                          |
| • Stainless steel front kicking strip, 400mm width   | PNC 912594 | <input type="checkbox"/> |   |            |                          |
| • Stainless steel side kicking strips left and right, freestanding, 800mm width  | PNC 912619 | <input type="checkbox"/> |   |            |                          |
| • Stainless steel side kicking strips left and right, back-to-back, 1610mm width   | PNC 912625 | <input type="checkbox"/> |   |            |                          |
| • Stainless steel plinth, freestanding, 400mm width  | PNC 912821 | <input type="checkbox"/> |   |            |                          |
| • Connecting rail kit: modular 80 (on the left) to ProThermetic tilting (on the right), ProThermetic stationary (on the left) to ProThermetic (on the right) | PNC 912971 | <input type="checkbox"/> |   |            |                          |
| • Connecting rail kit: modular 80 (on the right) to ProThermetic tilting (on the left), ProThermetic stationary (on the right) to ProThermetic (on the left) | PNC 912972 | <input type="checkbox"/> |   |            |                          |
| • Endrail kit, flush-fitting, left   | PNC 913109 | <input type="checkbox"/> |   |            |                          |
| • Endrail kit, flush-fitting, right  | PNC 913110 | <input type="checkbox"/> |   |            |                          |
| • Filter for deep fat fryer oil collection basin   | PNC 913146 | <input type="checkbox"/> |   |            |                          |
| • Endrail kit (12.5mm) for thermaline 80 units, left   | PNC 913200 | <input type="checkbox"/> |   |            |                          |
| • Endrail kit (12.5mm) for thermaline 80 units, right  | PNC 913201 | <input type="checkbox"/> |   |            |                          |
| • Stainless steel side panel, left, h=800  | PNC 913216 | <input type="checkbox"/> |   |            |                          |
| • Stainless steel side panel, right, h=800   | PNC 913217 | <input type="checkbox"/> |   |            |                          |
| • T-connection rail for back-to-back installations without backsplash (to be ordered as S-code)  | PNC 913227 | <input type="checkbox"/> |   |            |                          |
| • Insert profile D=800mm   | PNC 913230 | <input type="checkbox"/> |   |            |                          |
| • Energy optimizer kit 18A - factory fitted  | PNC 913245 | <input type="checkbox"/> |   |            |                          |
| • Endrail kit, (12.5mm), for back-to-back installation, left   | PNC 913249 | <input type="checkbox"/> |   |            |                          |